

Model R

Fig. 81-H Standard Constant Support A, B, C, D, E, F, G

Fig. 81-C-H Corrosion Resistant Constant Support A, B, C, D, E, F, G

Finish: Standard finish; painted with semi gloss primer. Corrosion resistant; galvanized with coated coil or painted with CZ11 and coated coil.

Recommended Service: When piping stress is critical and pipe is subject to vertical movement in excess of ½" due to thermal expansion, and also at locations where it is necessary to avoid any transfer of stress from support or onto critical terminals or connecting equipment.

Approvals: WW-H-171E (Types 52, 58 and 59), ANSI/MSS SP-69 and MSS SP-58 (Types 54, 55 and 56).

Features:

- Because of exclusive geometric design, mathematically perfect constancy of support is maintained throughout the full range of load adjustment.
- Compactness – design provides smaller and more versatile units
- Increased load and travel capacity.
- Each hanger is individually calibrated before shipment to support the exact load specified.
- All model R constant supports have a wide range of load adjustability. No less than 10% of this adjustability is provided either side of the calibrated load.
- White button marked "C" denotes cold setting of hanger; red button marked "H" denotes hot or operating setting.
- Field load adjustment is made by turning the single load adjustment bolt.
- Covered spring provides protection and good appearance.
- J-rod swings at least 4° from vertical.
- Non-resonant to all vertical vibrations.

Size Range: Anvil Model R constant support hangers are made in two basic designs, 80-V (vertical design) and 81-H (horizontal design). Combined, the 80-V and 81-H constant supports are made in nine different frame sizes and 110 spring sizes to accommodate travels from 1½" to 20" and loads from 27 lbs to 87,500 lbs.

Single Rod Suspension: Available in Types A, B and C, Fig. 80-V and Fig. 81-H.

How to Select Hanger Sizes:

Determine the total load to be supported by the hanger as well as the actual travel – that is, the actual vertical movement of the pipe at the point of hanger location. Refer to the Load-Travel table for constant support hangers in the Pipe Hanger Catalog and select a size hanger which will accommodate the known load and actual travel. It must be noted that the travel shown in the table is a total travel – that is, the maximum vertical movement which the hanger will accommodate. The total travel of the hanger should always be greater than the calculated travel of pipe line to allow for some discrepancy between calculated travel and actual travel.

It is suggested that the total travel for constant supports should be equal to "actual travel" plus 1" or 20% whichever is greater.

How to Determine Type: After the size of the constant support is determined, consideration of available room for suspending the pipe and hanger will indicate whether a vertical 80-V series or horizontal 81-H series hanger is desirable.

How to Determine Design: After the hanger size and design are determined, the type of constant support to be used depends upon the physical installation required by the suspension problem, i.e., whether the hanger is to be installed above, between or below steel members (see line cuts referring to Types A, B, C, etc.). It will be noted that the Type F is made in horizontal design only and the type G is made in the vertical design only. **Special constant support hangers can be fabricated for unusual conditions.**

J-Rod and K-Hole Diameter: Tapping or drilling for standard rod size will be furnished as shown in the J-rod and K-hole selection charts unless otherwise specified. Upper attachments, turnbuckles and clamps should be tapped to agree with the rod as shown in the selection chart. Standard rod diameters are based on the load to be carried by the upper rod which includes the weight of the hanger assembly as well as the pipe line. Tapped connections for hanger rod sizes 3" and smaller are UNC-Thread Series, Class 2 fit. 3¼" and large rod tappings are 8UN Series Threads.



Model R Fig. 81-H Horizontal

PROJECT INFORMATION	APPROVAL STAMP
Project:	Approved
Address:	Approved as noted
Contractor:	Not approved
Engineer:	Remarks:
Submittal Date:	
Notes 1:	
Notes 2:	

Model R

Fig. 81-H Standard Constant Support

Fig. 81-C-H Corrosion Resistant Constant Support

Ordering: Specify:

1. Hanger size number
2. Figure number
3. Type
4. Name of hanger
5. Loads to be supported (pounds)
6. Total travel (inches)
7. Actual travel (inches)
8. Direction of movement "cold to hot"
9. Customer's hanger mark.
10. When ordering Type G, specify C-C rod dimension as well as load per spring and total load
11. For Types A, B, C, Fig. 81-H when required specify "for single rod suspension"
12. Constant Support Hangers are also available corrosion-resistant as figures C-80-V and C-81-H

Installation:

1. Securely attach the hanger to the building structure at a point where the load coupling is directly over the desired point of attachment to the pipe in the operating position.
2. Make certain that the moving parts of the hanger will be unobstructed.
3. Attach the lower J-rod between the pipe attachment and the load coupling. Make certain that the lower J-rod has enough thread engagement before taking up the load. A sight hole is provided for this.
4. Turn the load coupling, as you would a turnbuckle, until the travel indicator rotates to the desired cold setting (white button) marked "C" indicated on the position scale. If the constant support incorporates a travel stop see below.
5. After the line is in operation, check hanger for indicated hot setting. If necessary, make adjustment by turning the load coupling to bring the indicator to the hot position (red button) marked "H". No other adjustment is normally required since the load as calibrated at the factory is equal to the load specified to be supported.

Adjustment: When the hanger is installed, its supporting force should be in balance with the portion of the piping weight assigned to it. Each hanger is individually calibrated before shipment to support the exact load specified. All model "R" Constant Supports have a wide range of load adjustability. Special instructions for field recalibration of individual hangers may be obtained from Anvil representatives. No less than 10% adjustability is provided either side of the calibrated load for plus or minus field load adjustment. The percentage increase or decrease from the factory calibrated load should be carefully calculated. The calibrated load setting of each hanger is indicated by a die-stamp on the load adjustment scale. Load adjustments should be made from this reference point, with

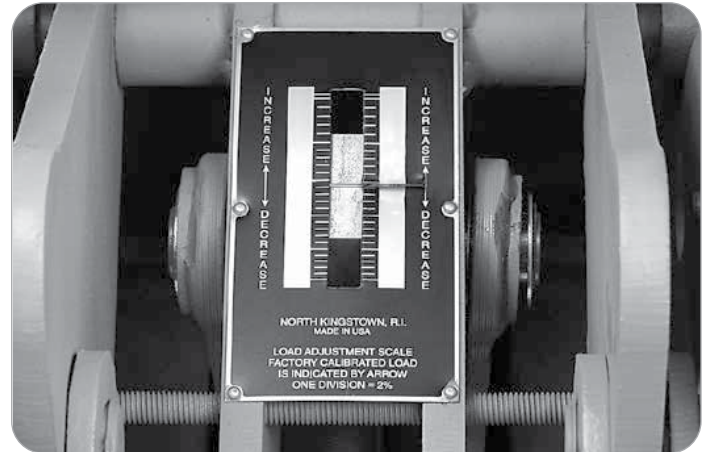

Load adjustment scale shown applies to size 1 through 83 only. The load adjustment scale for sizes 84 through 110 1 division equals 1%.

each division on the patented scale equal to 2% except sizes 84-110 where each division is valued at 1%. The load adjustment is made by turning the single load adjustment bolt. For example, a calibrated load of 3,000 pounds revised to 2,760 pounds is a decrease of 240 pounds. $240/3,000 = 8\%$. By turning the load adjusting bolt the arrow moves in the "Decrease" direction four divisions.

Note: Field Recalibration of load does not decrease total travel.

Travel stop: The functional design of the Constant Support Hanger permits the incorporation of a travel stop that will lock the hanger against upward or downward movement for temporary conditions of underload or overload, such as may exist during erection, hydrostatic test or chemical clean-out. Anvil Constant Supports are designed for hydrostatic test load of at least 2 times the normal operating load for the Constant Support. The travel stop for sizes 19 - 110 consists of two plates, with matched serrations, attached to the hanger frame with two or more cap screws and with a socketed piece which engages the position indicator. It is installed at the factory to hold the hanger in the "cold" position. A series of serrations can be engaged to lock the hanger at any position along the total travel range. The travel stop, which is furnished only when specified, is painted red. The stop must be removed before the piping system is put into operation, but not before the hanger is installed and fully loaded. The travel stop is released by removing the cap screws. A tag marked "Caution" and containing instructions for removal of the travel stop is attached to the hanger.

Note: See installation procedures PE-217-80 for a travel stop description on sizes 1-18.



Model R

Fig. 81-H Standard Constant Support

Fig. 81-C-H Corrosion Resistant Constant Support

Model R Lifting Lugs:

To help alleviate the problem of lifting large size Constant Supports into position for installation, this product is available with lifting lugs (if requested) on sizes ten and larger.

Lifting Lugs (Fig. 81-H): Not available on Type F.

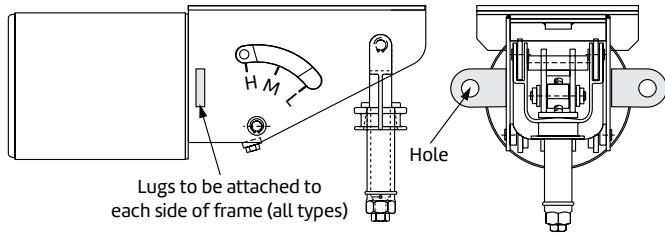
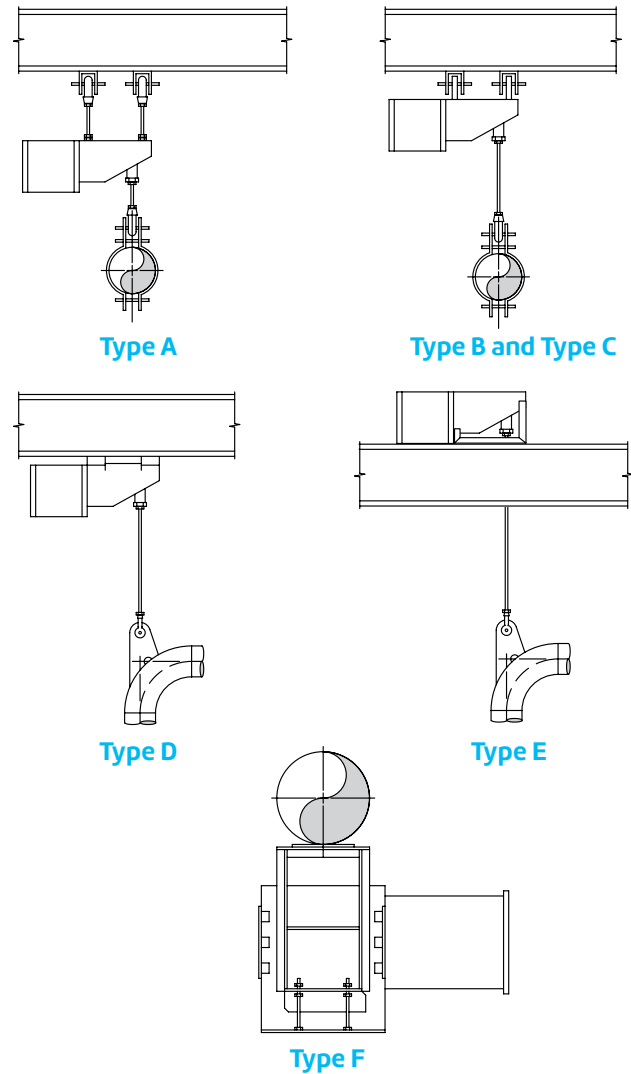

Fig. 81-H: (Horizontal) Typical Applications



Lifting Lugs (Fig. 80-V):

LUGS TO BE 90° FROM CHANNEL ON TYPE D

Types A, B, C, D, & E
Sizes 10 thru 63

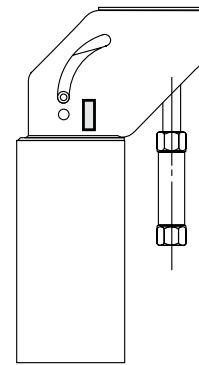
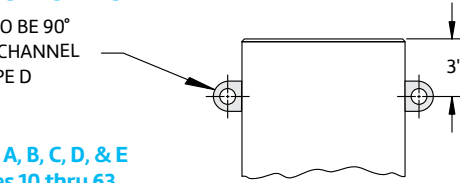

Sizes 84 thru 110

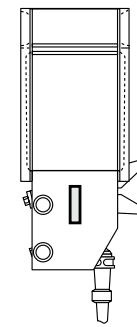

Sizes 64 thru 83
Lugs to be attached to each side of frame and will need stabilizing rigging when being lifted.

Fig. 80V: (Vertical) Typical Applications

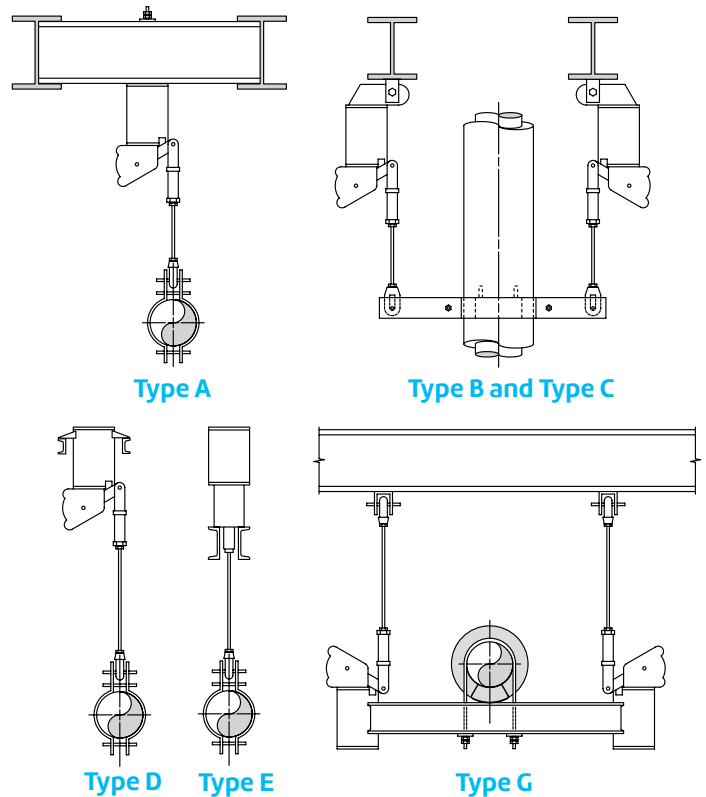

Model R Fig. 81-H Type A

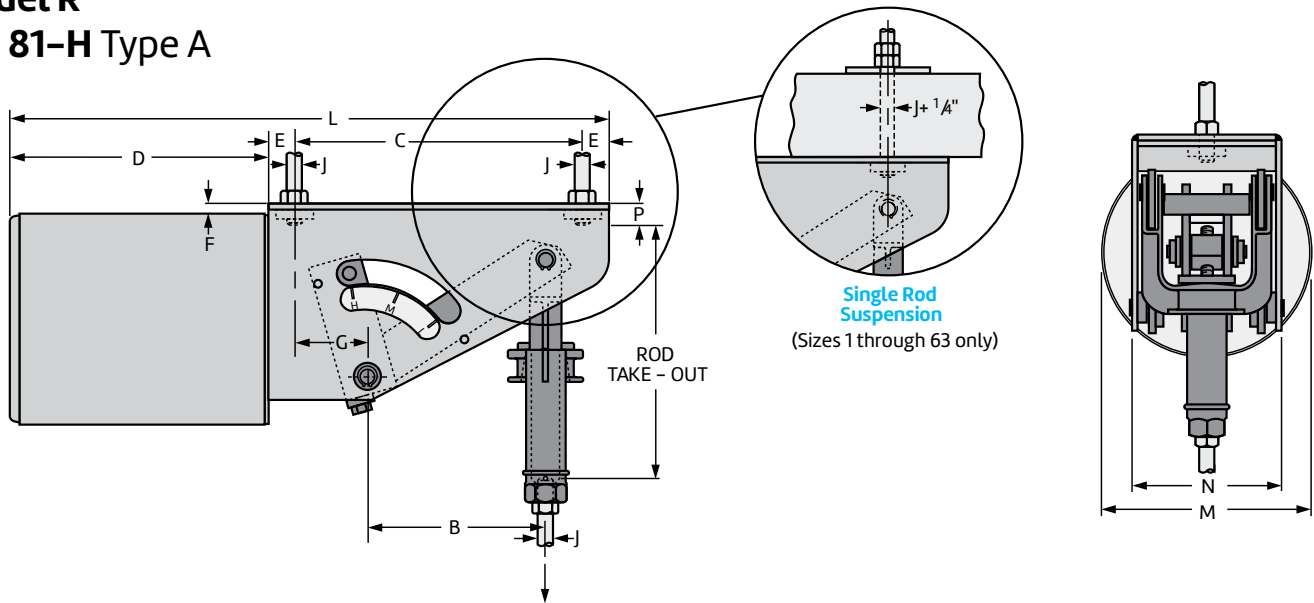

Type A of the Figure 81- H Horizontal Design Model R Constant Support Hanger is designed for attaching to its supporting member by screwing two rods into tapped holes in the top of the hanger from a distance equal to the "P" dimension plus $\frac{3}{8}$ ". Sizes 1 to 9 are furnished with swivel eye and turnbuckle instead of yoke and coupling.

Notes: Also available for single rod suspension as indicated above. When ordering specify " for single rod suspension". See load travel tables in the Pipe Hanger Catalog for the "B" dimension. For weights, see page 11 of this submittal. Location of travel indicator and contour of side plate may vary from that shown.

Fig. 81-H Type A: Dimensions (In)

Hanger Sizes	D	E	F	G	M	N	P	Total Travel TT	L	C	Factors	J-Rod	
												Min Thread Length	Rod Diameter Min Max
1-9	8 $\frac{1}{4}$	1	$\frac{7}{8}$	2	6 $\frac{1}{8}$	4 $\frac{1}{8}$	$\frac{13}{16}$	4 or less 4 $\frac{1}{2}$ or more	16 $\frac{1}{4}$ 20 $\frac{1}{4}$	6 10	12 $\frac{3}{4}$ 15 $\frac{5}{16}$	1 $\frac{3}{4}$ + TT	$\frac{1}{2}$ $\frac{1}{2}$
10-18	8 $\frac{7}{16}$	1	$\frac{1}{2}$	2 $\frac{9}{16}$	8 $\frac{5}{16}$	6 $\frac{7}{16}$	$\frac{11}{16}$	5 or less 5 $\frac{1}{2}$ or more	18 $\frac{7}{16}$ 21 $\frac{7}{16}$	8 11	10 $\frac{7}{8}$ 13 $\frac{1}{4}$	1 $\frac{3}{4}$ + TT	$\frac{1}{2}$ $\frac{3}{4}$
19-34	14 $\frac{7}{16}$	1 $\frac{1}{4}$	$\frac{5}{8}$	3 $\frac{7}{8}$	12 $\frac{7}{16}$	8 $\frac{9}{16}$	1 $\frac{1}{8}$	5 or less 5 $\frac{1}{2}$ or more	26 $\frac{15}{16}$ 31 $\frac{1}{16}$	10 14 $\frac{1}{8}$	16 $\frac{3}{4}$ 18 $\frac{7}{8}$	2 $\frac{3}{8}$ + TT	$\frac{1}{2}$ 1 $\frac{1}{4}$
35-49	17 $\frac{7}{16}$	1 $\frac{3}{4}$	$\frac{11}{16}$	4 $\frac{3}{4}$	13 $\frac{3}{4}$	9 $\frac{13}{16}$	1 $\frac{3}{8}$	6 or less 6 $\frac{1}{2}$ or more	31 $\frac{9}{16}$ 39 $\frac{9}{16}$	11 19	21 $\frac{1}{8}$ 25 $\frac{3}{4}$	3 $\frac{1}{4}$ + TT	$\frac{1}{2}$ 1 $\frac{3}{4}$
50-63	26 $\frac{3}{16}$	1 $\frac{11}{16}$	$\frac{15}{16}$	7 $\frac{11}{16}$	17 $\frac{11}{16}$	11 $\frac{1}{4}$	1 $\frac{3}{4}$	8 or less 8 $\frac{1}{2}$ to 11 11 $\frac{1}{2}$ or more	45 $\frac{9}{16}$ 53 $\frac{9}{16}$ 53 $\frac{9}{16}$	16 24 24	24 $\frac{15}{16}$ 24 $\frac{15}{16}$ 30 $\frac{1}{4}$	4 $\frac{1}{4}$ + TT	$\frac{3}{4}$ 2 $\frac{1}{4}$
64-74	35 $\frac{3}{4}$	3	3 $\frac{1}{4}$	5 $\frac{1}{4}$	22 $\frac{3}{16}$	11	3 $\frac{7}{16}$	10 $\frac{1}{2}$ or less 11 or more	57 $\frac{1}{2}$ 63	15 $\frac{3}{4}$ 21 $\frac{1}{4}$	34 $\frac{7}{16}$ 34 $\frac{9}{16}$	5 $\frac{3}{4}$ + TT	1 $\frac{1}{4}$ 2 $\frac{3}{4}$
75-83	35 $\frac{3}{4}$	3 $\frac{1}{4}$	3 $\frac{5}{8}$	5	27 $\frac{3}{16}$	11	4 $\frac{1}{4}$	10 $\frac{1}{2}$ or less 11 or more	57 $\frac{1}{2}$ 63	15 $\frac{1}{4}$ 20 $\frac{3}{4}$	36 $\frac{1}{2}$ 36 $\frac{5}{8}$	5 $\frac{3}{4}$ + TT	1 $\frac{1}{2}$ 3 $\frac{1}{4}$
84-110	See page 10 of submittal.												

* Rod take-out = (factor)-(TT / 2) for lever in high position.

J-Rod Selection Chart

Load (lbs)	0 800	801 1,500	1,501 2,540	2,541 4,000	4,001 6,100	6,101 9,400	9,401 13,400	13,401 18,300	18,301 24,700	24,701 31,000	31,001 39,000	39,001 48,000	48,001 58,000
Rod Size	$\frac{1}{2}$	$\frac{5}{8}$	$\frac{3}{4}$	1	1 $\frac{1}{4}$	1 $\frac{1}{2}$	1 $\frac{3}{4}$	2	2 $\frac{1}{4}$	2 $\frac{1}{2}$	2 $\frac{3}{4}$	3	3 $\frac{1}{4}$ *

* 3 $\frac{1}{4}$ " is furnished with 4 UNC series thread.

Model R

Fig. 81-H Type B

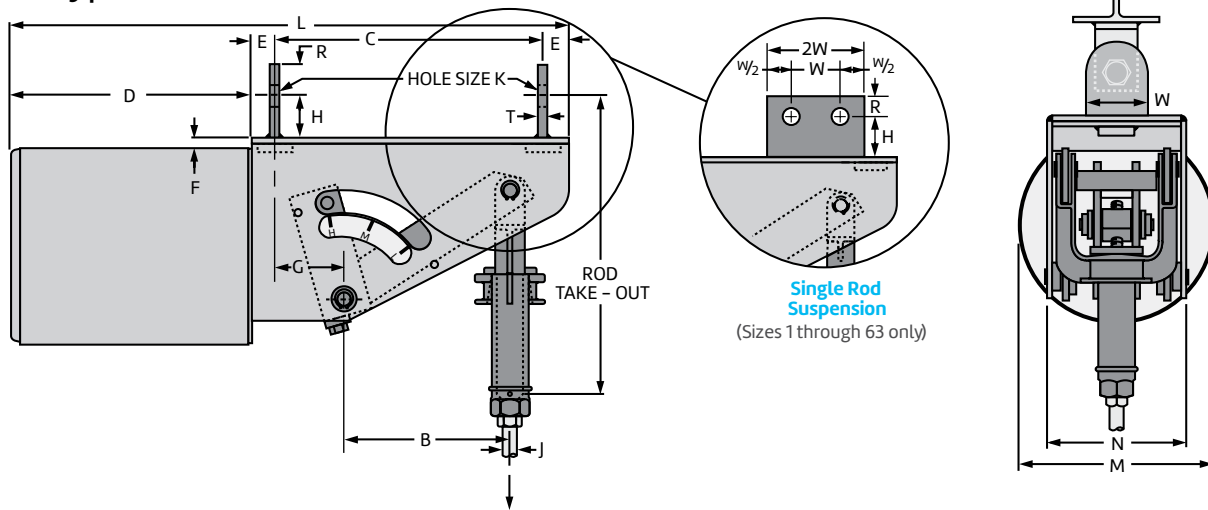

Type B is furnished with two lugs – one at each end of the hanger frame. These lugs permit use of Fig. 66 welded beam attachments, clevises or angle clips for attachment where headroom is limited. Sizes 1 to 9 are furnished with swivel eye and turnbuckle instead of yoke and coupling.

Notes: Also available for single rod suspension as indicated above. When ordering specify "for single rod suspension." See load travel tables in the Pipe Hanger Catalog for the "B" dimension. For weights, see page 11 of this submittal. Location of travel indicator and contour of side plate may vary from that shown.

Fig. 81-H Type B: Dimensions (In)

Hanger Sizes	D	E	F	G	H	M	N	Total Travel TT	L	C	Factors	J-Rod	
												Min Thread Length	Rod Diameter Min Max
1-9	8 ¹ / ₄	1 ¹ / ₄	7 ⁷ / ₈	1 ³ / ₄	1 ¹ / ₂	6 ¹ / ₈	4 ¹ / ₈	4 or less 4 ¹ / ₂ or more	16 ¹ / ₄ 20 ¹ / ₄	5 ¹ / ₂ 9 ¹ / ₂	14 ⁵ / ₈ 17 ³ / ₁₆	1 ³ / ₄ + TT	1/2 1/2
10-18	8 ⁷ / ₁₆	1 ¹ / ₄	1/2	2 ⁵ / ₁₆	1 ¹ / ₂	8 ⁵ / ₁₆	6 ⁷ / ₁₆	5 or less 5 ¹ / ₂ or more	18 ⁷ / ₁₆ 21 ⁷ / ₁₆	7 ¹ / ₂ 10 ¹ / ₂	13 ¹ / ₁₆ 15 ⁷ / ₁₆	1 ³ / ₄ + TT	1/2 3/4
19-34	14 ⁷ / ₁₆	1 ³ / ₈	5 ⁵ / ₈	3 ³ / ₄	2	12 ⁷ / ₈	8 ⁹ / ₁₆	5 or less 5 ¹ / ₂ or more	26 ¹⁵ / ₁₆ 31 ¹ / ₁₆	9 ³ / ₄ 13 ⁷ / ₈	19 ⁷ / ₈ 22	2 ³ / ₈ + TT	1/2 1 ¹ / ₄
35-49	16 ¹³ / ₁₆	2	1 ¹ / ₁₆	4 ¹ / ₂	3	13 ³ / ₄	9 ¹³ / ₁₆	6 or less 6 ¹ / ₂ or more	31 ⁹ / ₁₆ 39 ⁹ / ₁₆	10 ¹ / ₂ 18 ¹ / ₂	25 ⁵ / ₈ 30 ¹ / ₈	3 ¹ / ₄ + TT	1/2 1 ³ / ₄
50-63	26 ³ / ₁₆	3	1 ⁵ / ₁₆	6 ³ / ₈	4	17 ³ / ₈	11 ¹ / ₄	8 or less 8 ¹ / ₂ to 11 11 ¹ / ₂ or more	45 ⁹ / ₁₆ 53 ⁹ / ₁₆ 53 ⁹ / ₁₆	13 ³ / ₈ 21 ³ / ₈ 21 ³ / ₈	30 ¹¹ / ₁₆ 30 ¹¹ / ₁₆ 36	4 ¹ / ₄ + TT	3/4 2 ¹ / ₄
64-74	35 ³ / ₄	3 ¹ / ₄	3 ¹ / ₄	5	4 ¹ / ₂	22 ³ / ₁₆	11	10 ¹ / ₂ or less 11 or more	57 ¹ / ₂ 63	15 ¹ / ₄ 20 ³ / ₄	42 ³ / ₈ 42 ¹ / ₂	5 ³ / ₄ + TT	1 ¹ / ₄ 2 ³ / ₄
75-83	35 ³ / ₄	3 ¹ / ₂	3 ⁵ / ₈	4 ³ / ₄	5	27 ³ / ₁₆	11	10 ¹ / ₂ or less 11 or more	57 ¹ / ₂ 63	14 ³ / ₄ 20 ¹ / ₄	45 ³ / ₄ 45 ⁷ / ₈	5 ³ / ₄ + TT	1 ¹ / ₂ 3 ¹ / ₄ **
84-110	See page 10 of submittal.												

*Rod take-out = (factor) - (TT / 2) for lever in high position.

J-Rod and K-Hole Selection Chart

Load (lbs)	0 800	801 1,500	1,501 2,540	2,541 4,000	4,001 6,100	6,101 9,400	9,401 13,400	13,401 18,300	18,301 24,700	24,701 31,000	31,001 39,000	39,001 48,000	48,001 58,000
J-rod	1/2	5/8	3/4	1	1 ¹ / ₄	1 ¹ / ₂	1 ³ / ₄	2	2 ¹ / ₄	2 ¹ / ₂	2 ³ / ₄	3	3 ¹ / ₄ **
K-Hole Size	1 ¹ / ₁₆	1 ³ / ₁₆	1 ⁵ / ₁₆	1 ¹ / ₄	1 ³ / ₄	1 ³ / ₄	2	2 ³ / ₈	2 ⁵ / ₈	2 ⁷ / ₈	3 ¹ / ₈	3 ³ / ₈	3 ⁵ / ₈
R	1 ¹ / ₄	1 ¹ / ₄	1 ¹ / ₄	1 ¹ / ₂	2	2 ¹ / ₂	2 ¹ / ₂	3	3	4	4	4	4 ¹ / ₂
T	1/4*	1/4*	3/8	1/2	5/8	3/4	3/4	3/4	3/4	1	1	1	1
W	2 ¹ / ₂	2 ¹ / ₂	2 ¹ / ₂	3	4	5	5	6	6	8	8	8	9

** 3¹/₄" is furnished with 4 UNC series thread.

* 3/8" for single rod suspension.

Model R Fig. 81-H Type C

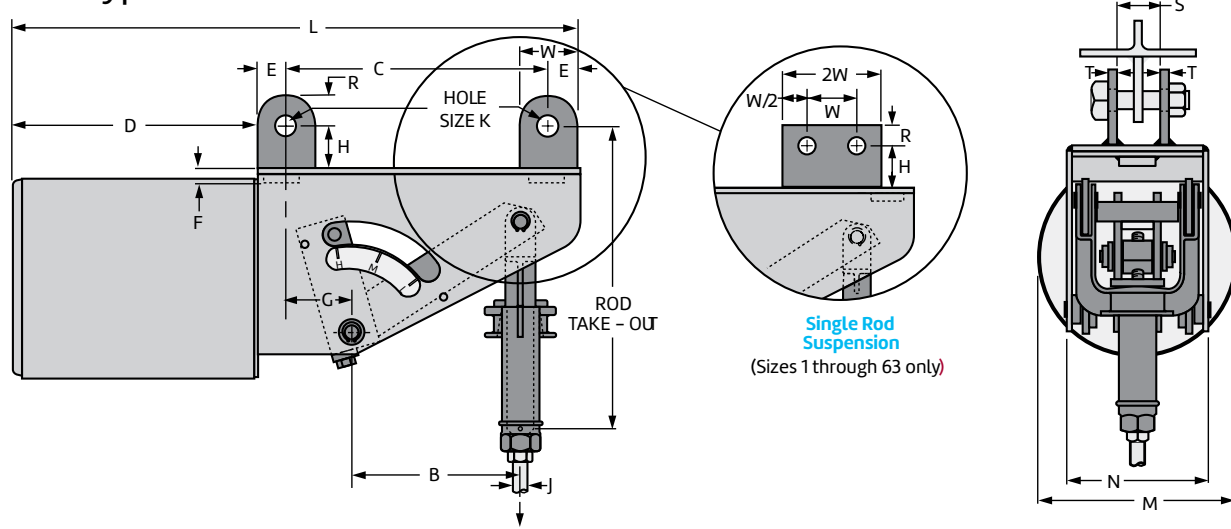

Type C is furnished with two lugs – one at each end of the hanger frame. These lugs permit the use of two eye rods or two single plates for attachment where headroom is limited. Sizes 1 to 9 are furnished with swivel eye and turnbuckle instead of yoke and coupling.

Notes: Also available for single rod suspension as indicated above. When ordering specify "for single rod suspension." See load travel tables in the Pipe Hanger Catalog for the "B" dimension. For weights, see page 11 of this submittal. Location of travel indicator and contour of side plate may vary from that shown.

Fig. 81-H Type C: Dimensions (In)

Hanger Sizes	D	E	F	G	H	M	N	Total Travel TT	L	C	Factors	J-Rod		
												Min Thread Length	Rod Diameter Min Max	
1-9	8 ¹ / ₄	1 ¹ / ₄	7 ⁷ / ₈	1 ³ / ₄	1 ¹ / ₂	6 ¹ / ₈	4 ¹ / ₈	4 or less	16 ¹ / ₄	5 ¹ / ₂	14 ⁵ / ₈	1 ³ / ₄ + TT	1/2	1/2
								4 ¹ / ₂ or more	20 ¹ / ₄	9 ¹ / ₂	17 ³ / ₁₆			
10-18	8 ⁷ / ₁₆	1 ¹ / ₄	1/2	2 ⁵ / ₁₆	1 ¹ / ₂	8 ⁵ / ₁₆	6 ⁷ / ₁₆	5 or less	18 ⁷ / ₁₆	7 ¹ / ₂	13 ¹ / ₁₆	1 ³ / ₄ + TT	1/2	3/4
								5 ¹ / ₂ or more	21 ⁷ / ₁₆	10 ¹ / ₂	15 ⁷ / ₁₆			
19-34	14 ⁷ / ₁₆	2	5/8	3 ¹ / ₈	2	12 ⁷ / ₁₆	8 ⁹ / ₁₆	5 or less	26 ¹⁵ / ₁₆	8 ¹ / ₂	19 ⁷ / ₈	2 ³ / ₈ + TT	1/2	1 ¹ / ₄
								5 ¹ / ₂ or more	31 ¹ / ₁₆	12 ⁵ / ₈	22			
35-49	17 ¹ / ₁₆	2 ¹ / ₂	1 ¹ / ₁₆	4	3	13 ³ / ₄	9 ¹³ / ₁₆	6 or less	31 ⁹ / ₁₆	9 ¹ / ₂	25 ⁵ / ₈	3 ¹ / ₄ + TT	1/2	1 ³ / ₄
								6 ¹ / ₂ or more	39 ⁹ / ₁₆	17 ¹ / ₂	30 ¹ / ₈			
50-63	26 ³ / ₁₆	3	1 ⁵ / ₁₆	6 ³ / ₈	4	17 ¹¹ / ₁₆	11 ¹ / ₄	8 or less	45 ⁹ / ₁₆	13 ³ / ₈	30 ¹¹ / ₁₆	4 ¹ / ₄ + TT	3/4	2 ¹ / ₄
								11 ¹ / ₂ or more	53 ⁹ / ₁₆	21 ³ / ₈	36			
64-74	35 ³ / ₄	4	3 ¹ / ₄	4 ¹ / ₄	4 ¹ / ₂	22 ³ / ₁₆	11	10 ¹ / ₂ or less	57 ¹ / ₂	13 ³ / ₄	42 ³ / ₈	5 ³ / ₄ + TT	1 ¹ / ₄	2 ³ / ₄
								11 or more	63	19 ¹ / ₄	42 ¹ / ₂			
75-83	35 ³ / ₄	4 ¹ / ₂	3 ⁵ / ₈	3 ³ / ₄	5	27 ³ / ₁₆	11	10 ¹ / ₂ or less	57 ¹ / ₂	12 ³ / ₄	45 ³ / ₄	5 ³ / ₄ + TT	1 ¹ / ₂	3 ¹ / ₄
								11 or more	63	18 ¹ / ₄	45 ³ / ₄			
84-110	See page 10 of submittal.													

* Rod take-out = (factor) - (TT / 2) for lever in high position.

J-Rod and K-Hole Selection Chart

Load (lbs)	0 800	801 1,500	1,501 2,540	2,541 4,000	4,001 6,100	6,101 9,400	9,401 13,400	13,401 18,300	18,301 24,700	24,701 31,000	31,001 39,000	39,001 48,000	48,001 58,000
J-Rod	1/2	5/8	3/4	1	1 ¹ / ₄	1 ¹ / ₂	1 ³ / ₄	2	2 ¹ / ₄	2 ¹ / ₂	2 ³ / ₄	3	3 ¹ / ₄ **
K-Hole Size	1 ¹ / ₁₆	1 ³ / ₁₆	1 ⁵ / ₁₆	1 ¹ / ₄	1 ¹ / ₂	1 ³ / ₄	2	2 ³ / ₈	2 ⁵ / ₈	2 ⁷ / ₈	3 ¹ / ₈	3 ³ / ₈	3 ⁵ / ₈
R	1 ¹ / ₄	1 ¹ / ₄	1 ¹ / ₄	1 ¹ / ₂	2	2 ¹ / ₂	2 ¹ / ₂	3	3	4	4	4	4 ¹ / ₂
S	7/8	1 ¹ / ₁₆	1 ¹ / ₄	1 ⁵ / ₈	2	2 ³ / ₈	2 ⁵ / ₈	2 ⁷ / ₈	3 ¹ / ₈	3 ³ / ₈	3 ⁵ / ₈	3 ⁷ / ₈	4 ¹ / ₈
T	1/4*	1/4*	3/8	1/2	5/8	3/4	3/4	3/4	3/4	1	1	1	1
W	2 ¹ / ₂	2 ¹ / ₂	2 ¹ / ₂	3	4	5	5	6	6	8	8	8	9

** 3¹/₄" is furnished with 4 UNC series thread. * 3/8" for single rod suspension.

Model R Fig. 81-H Type D

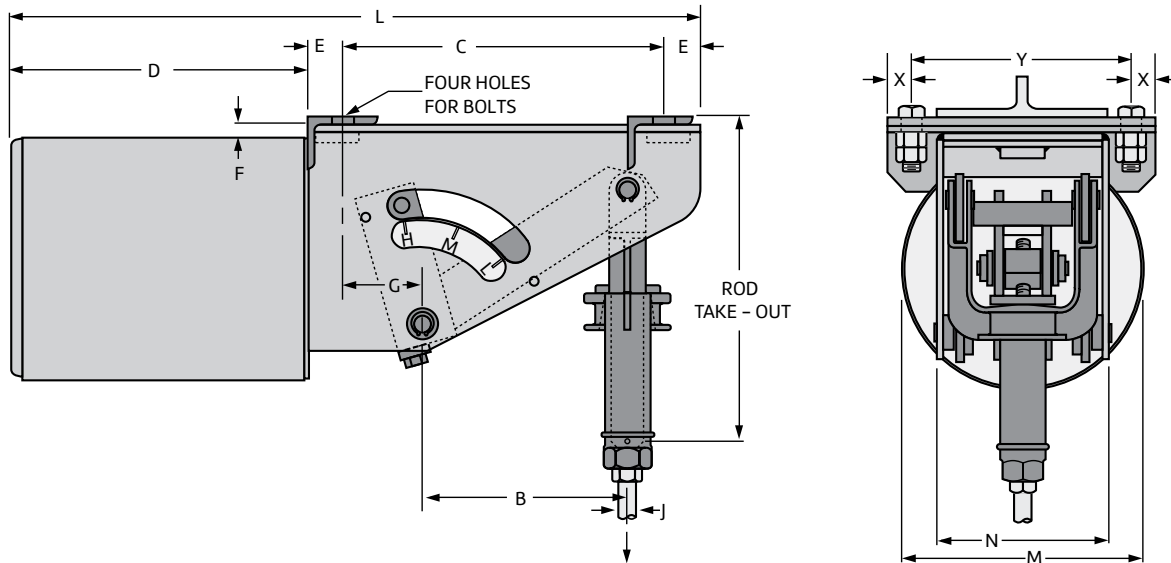

Type D may be bolted directly under steel. Sizes 1 to 9 are furnished with swivel eye and turnbuckle instead of yoke and coupling.

Notes: See load travel tables in the Pipe Hanger Catalog for the "B" dimension. For weights, see page 11 of this submittal. Location of travel indicator and contour of side plate may vary from that shown.

Fig. 81-H Type D: Dimensions (In)

Hanger Sizes	D	E	F	G	M	N	X	Y	Angle Size	Bracket Hole Dia.	Total Travel TT	L	C	Factors	J-Rod		
															Min Thread Length	Rod Diameter	
															Min	Max	
1-9	8 ¹ / ₄	1	7 ⁷ / ₈	2	6 ¹ / ₈	4 ¹ / ₈	3 ³ / ₄	5 ⁵ / ₈	2 x 2 x 1 ¹ / ₄	9 ⁹ / ₁₆	4 or less	16 ¹ / ₄	6	13 ³ / ₈	1 ³ / ₄ + TT	1 ¹ / ₂	1 ¹ / ₂
											4 ¹ / ₂ or more	20 ³ / ₄	10	15 ¹⁵ / ₁₆			
10-18	8 ⁷ / ₁₆	3 ³ / ₄	1 ¹ / ₂	5 ⁵ / ₁₆	8 ⁵ / ₁₆	6 ⁷ / ₁₆	7 ⁷ / ₈	8 ¹ / ₁₆	1 ¹ / ₂ x 1 ¹ / ₂ x 1 ¹ / ₄	3 ³ / ₄	5 or less	18 ⁷ / ₁₆	3 ¹ / ₂	11 ¹³ / ₁₆	1 ³ / ₄ + TT	1 ¹ / ₂	3 ³ / ₄
											5 ¹ / ₂ or more	21 ⁷ / ₁₆	6	14 ³ / ₁₆			
19-34	14 ⁷ / ₁₆	1 ¹ / ₂	5 ⁵ / ₈	3 ³ / ₈	12 ⁷ / ₁₆	8 ⁹ / ₁₆	1 ¹ / ₈	11 ⁵ / ₁₆	3 x 3 ¹ / ₂ x 1 ¹ / ₄	3 ³ / ₄	5 or less	26 ¹⁵ / ₁₆	9 ¹ / ₂	17 ³ / ₄	2 ³ / ₈ + TT	1 ¹ / ₂	1 ¹ / ₄
											5 ¹ / ₂ or more	31 ¹ / ₁₆	13 ⁵ / ₈	19 ⁷ / ₈			
35-49	17 ¹ / ₁₆	2	11 ¹¹ / ₁₆	4 ¹ / ₂	13 ³ / ₄	9 ¹³ / ₁₆	1 ³ / ₈	13	3 x 4 x 3 ³ / ₈	7 ⁷ / ₈	6 or less	31 ¹ / ₁₆	10 ¹ / ₂	20 ¹³ / ₁₆	3 ¹ / ₄ + TT	1 ¹ / ₂	1 ³ / ₄
											6 ¹ / ₂ or more	39 ⁹ / ₁₆	18 ¹ / ₂	25 ⁷ / ₁₆			
50-63	26 ³ / ₁₆	2	1 ⁵ / ₁₆	7 ³ / ₈	17 ¹¹ / ₁₆	11 ¹ / ₄	1 ⁵ / ₈	14 ⁵ / ₈	4 x 4 x 3 ³ / ₈	1 ³ / ₈	8 or less	45 ⁹ / ₁₆	15 ³ / ₈	27 ¹ / ₁₆			
											8 ¹ / ₂ to 11	53 ⁹ / ₁₆	23 ³ / ₈	27 ¹ / ₁₆	4 ¹ / ₄ + TT	3 ³ / ₄	2 ¹ / ₄
											11 or more	53 ⁹ / ₁₆	23 ³ / ₈	32 ³ / ₈			
64-74	35 ³ / ₄	3	3 ³ / ₄	5 ¹ / ₄	22 ³ / ₁₆	11	2	15	4 x 6 x 1 ¹ / ₂	1 ⁵ / ₈	10 ¹ / ₂ or less	57 ¹ / ₂	15 ³ / ₄	38 ³ / ₈	5 ³ / ₄ + TT	1 ¹ / ₄	2 ³ / ₄
											11 or more	63	21 ¹ / ₄	38 ¹ / ₂			
75-83	35 ³ / ₄	3	3 ⁵ / ₈	4 ³ / ₄	27 ³ / ₁₆	11	2	15	4 x 6 x 1 ¹ / ₂	1 ⁵ / ₈	10 ¹ / ₂ or less	57 ¹ / ₂	15 ³ / ₄	41 ¹ / ₄	5 ³ / ₄ + TT	1 ¹ / ₂	3 ¹ / ₄
											11 or more	63	21 ¹ / ₄	41 ³ / ₈			
84-110	Not available																

*Rod take-out = (factor) - (TT / 2) for lever in high position.

J-Rod Selection Chart

Load (lbs)	0 800	801 1,500	1,501 2,540	2,541 4,000	4,001 6,100	6,101 9,400	9,401 13,400	13,401 18,300	18,301 24,700	24,701 31,000	31,001 39,000	39,001 48,000	48,001 58,000
J Rod Size	1/2	5/8	3/4	1	1 1/4	1 1/2	1 3/4	2	2 1/4	2 1/2	2 3/4	3	3 1/4*

* 3 1/4" is furnished with 4 UNC series thread.

Model R Fig. 81-H Type E

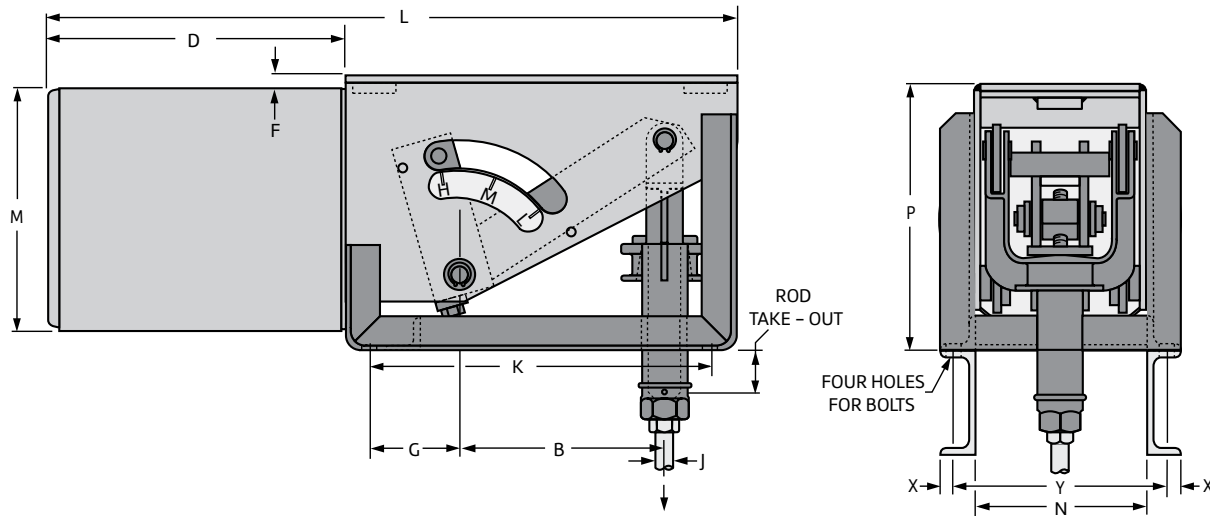

Type E incorporates two brackets as part of its frame, permitting the bolting of the constant support to the top of structural steel. Sizes 1 to 9 are furnished with swivel eye and turnbuckle instead of yoke and coupling. If rod take-out does not exceed the depth of the supporting steel and rod coupling is required to extend below the steel, specify the depth of the supporting steel. Increase rod take-out by the depth of the steel.

Notes: See load travel tables in the Pipe Hanger Catalog for the "B" dimension. For weights, see page 11 of this submittal. Location of travel indicator and contour of side plate may vary from that shown.

Fig. 81-H Type E: Dimensions (In)

Hanger Sizes	D	F	G	M	N	P	X	Y	Angle Size	Bracket Hole Dia.	Total Travel TT	L	C	Factors	J-Rod		
															Min Thread Length	Rod Diameter	
1-9	8 ¹ / ₄	1 ¹ / ₄	2	6 ¹ / ₈	4 ¹ / ₈	8 ¹ / ₂	5 ⁵ / ₈	5 ¹⁵ / ₁₆	1 ¹ / ₂ x 1 ¹ / ₂ x 1 ¹ / ₄	9 ¹ / ₁₆	4 or less	16 ¹ / ₄	6	5 ¹ / ₈	1 ³ / ₄ + TT	1/2	1/2
											4 ¹ / ₂ or more	20 ³ / ₄	10	7 ¹¹ / ₁₆			
10-18	8 ⁷ / ₁₆	1	2 ¹ / ₁₆	8 ⁵ / ₁₆	6 ⁷ / ₁₆	11 ⁷ / ₁₆	5 ⁵ / ₈	8 ¹⁵ / ₁₆	1 ¹ / ₂ x 2 x 1 ¹ / ₄	3 ³ / ₄	5 or less	18 ⁷ / ₁₆	7 ¹ / ₂	1 ³ / ₄	1 ³ / ₄ + TT	1/2	3/4
											5 ¹ / ₂ or more	21 ⁷ / ₁₆	7 ¹ / ₂	4 ¹ / ₁₆			
19-34	14 ⁷ / ₁₆	5 ⁵ / ₈	3 ⁵ / ₈	12 ⁷ / ₁₆	8 ⁹ / ₁₆	15 ¹ / ₈	5 ⁵ / ₈	11 ³ / ₁₆	1 ¹ / ₂ x 2 ¹ / ₂ x 1 ¹ / ₄	3 ³ / ₄	5 or less	26 ¹⁵ / ₁₆	10	3 ³ / ₈	2 ³ / ₈ + TT	1/2	1 ¹ / ₄
											5 ¹ / ₂ or more	31 ¹ / ₁₆	10	5 ¹ / ₂			
35-49	17 ¹ / ₁₆	1 ¹ / ₁₆	4 ¹ / ₂	13 ³ / ₄	9 ¹³ / ₁₆	19 ⁵ / ₈	1 ³ / ₁₆	13 ⁵ / ₁₆	3 x 2 x 3 ³ / ₈	7 ⁷ / ₈	6 or less	31 ⁹ / ₁₆	11 ⁵ / ₈	4 ⁷ / ₈	3 ¹ / ₄ + TT	1/2	1 ³ / ₄
											6 ¹ / ₂ or more	39 ⁹ / ₁₆	11 ⁵ / ₈	9 ¹ / ₂			
50-63	26 ³ / ₁₆	1 ⁵ / ₁₆	7 ³ / ₈	17 ¹¹ / ₁₆	11 ¹ / ₄	19 ³ / ₄	1 ⁵ / ₁₆	14 ¹¹ / ₁₆	3 x 3 x 3 ³ / ₈	1 ³ / ₈	8 or less	45 ⁹ / ₁₆	15 ³ / ₈	6 ⁷ / ₈	4 ¹ / ₄ + TT	3/4	2 ¹ / ₄
											8 ¹ / ₂ to 11	53 ⁹ / ₁₆	23 ³ / ₈	6 ⁷ / ₈			
											11 ¹ / ₂ or more	53 ⁹ / ₁₆	23 ³ / ₈	12 ¹ / ₄			
64-74	35 ³ / ₄	3 ¹ / ₄	5 ¹ / ₄	22 ³ / ₁₆	11	26 ⁷ / ₈	1 ⁹ / ₁₆	14 ¹⁵ / ₁₆	3 ¹ / ₂ x 3 ¹ / ₂ x 1 ¹ / ₂	1 ⁵ / ₈	10 ¹ / ₂ or less	57 ¹ / ₂	17 ¹ / ₂	11 ¹ / ₈	5 ³ / ₄ + TT	1 ¹ / ₄	2 ³ / ₄
											11 or more	63	23	11 ¹ / ₄			
75-83	35 ³ / ₄	3 ⁵ / ₈	4 ³ / ₄	27 ³ / ₁₆	11	31 ⁷ / ₈	1 ⁹ / ₁₆	14 ¹⁵ / ₁₆	3 ¹ / ₂ x 3 ¹ / ₂ x 1 ¹ / ₂	1 ⁵ / ₈	10 ¹ / ₂ or less	57 ¹ / ₂	17 ¹ / ₂	9	5 ³ / ₄ + TT	1 ¹ / ₂	3 ¹ / ₄
											11 or more	63	23	9 ¹ / ₈			
84-110	See page 10 of submittal.																

* Rod take-out = (factor) - (TT / 2) for lever in high position.

J-Rod Selection Chart

Load (lbs)	0 800	801 1,500	1,501 2,540	2,541 4,000	4,001 6,100	6,101 9,400	9,401 13,400	13,401 18,300	18,301 24,700	24,701 31,000	31,001 39,000	39,001 48,000	48,001 58,000
J Rod Size	1/2	5/8	3/4	1	1 1/4	1 1/2	1 3/4	2	2 1/4	2 1/2	2 3/4	3	3 1/4*

* 3 1/4" is furnished with 4 UNC series thread.

Model R

Fig. 81-H Type F Upthrust

Type F: The Upthrust is for support of piping or equipment from below. It has a base flange for fastening to the floor or beams. The load is supported during hydrostatic testing by means of (4) positioning studs. After testing the nuts are moved to either end of the stud to prevent interference during operation. The Upthrust constant support is available for loads up to 24,463 (lbs). Corrosion resistant units are available either galvanized or carbon-zinc painted.

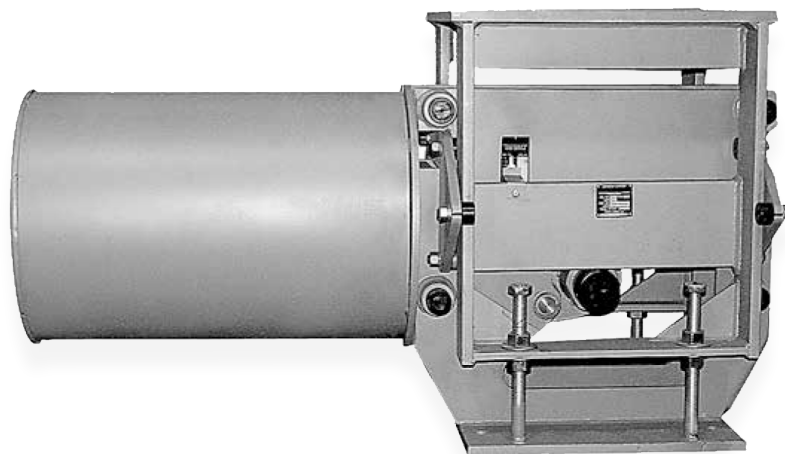

Take-Out Factor* "A"

T.T.	Sizes				
	10 - 18	19 - 34	35 - 49	50 - 63	64 - 74
2.0			-	-	-
2.5	16 ¹ / ₈			-	-
3.0					-
3.5		23 ¹ / ₈			-
4.0					
4.5			25 ³ / ₄		
5.0	19 ⁷ / ₈				28 ¹ / ₂
5.5					
6.0					
6.5	-	27 ¹ / ₂			
7.0	-				43 ¹ / ₄
7.5	-				
8.0	-		31 ⁵ / ₈	34	
8.5	-	-			
9.0	-	-			
9.5	-	-			
10.0	-	-			

For down travel: Take-Out = "A" + (1/2) Actual Travel
For up travel: Take-Out = "A" - (1/2) Actual Travel

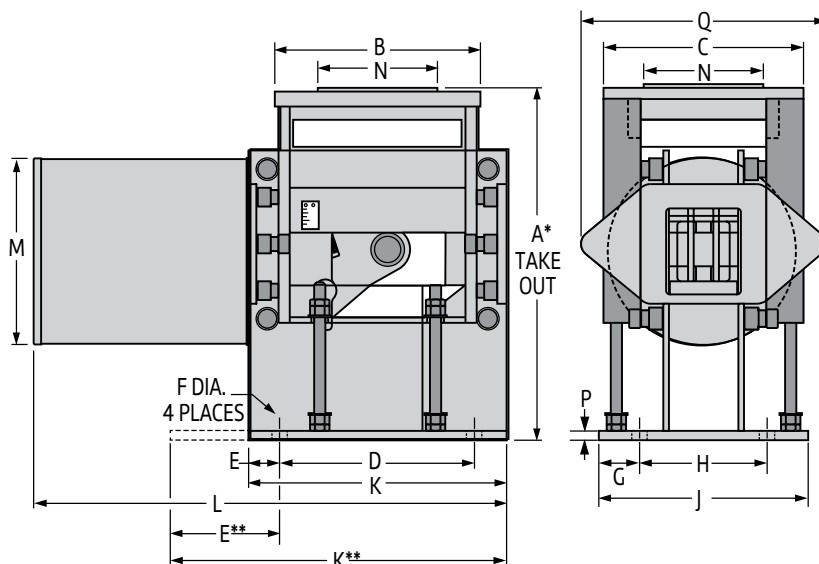

Notes: * Shorter "A" Dimensions are available upon request.
** For sizes 64 - 74 only.

Fig. 81-H Type F: Dimensions (In)

Size	Total Travel TT	A	B	C	D	E	F	G	H	J	K	L	M	N	P	Q
10 - 18	2 - 6		10 ⁷ / ₈	11 ⁷ / ₈	9	2 ¹ / ₂			8	12	14	22 ⁷ / ₁₆	8 ¹ / ₄	5	1 ¹ / ₂	13 ⁷ / ₈
19 - 34	2 - 8	See Take Out	13 ³ / ₄	13 ³ / ₄	13	2 ¹ / ₈		2	10	14	17 ¹ / ₄	31 ⁵ / ₈	12 ¹ / ₂	8	5 ⁵ / ₈	16 ³ / ₈
35 - 49	2 ¹ / ₂ - 10		17 ⁷ / ₈	16 ¹ / ₄	17	2				13	17	21	38 ³ / ₄		13 ⁵ / ₈	
50 - 63	3 - 10		21 ⁵ / ₈	19 ¹ / ₄	16 ¹ / ₂	4 ⁵ / ₈	7 ⁷ / ₈	3 ⁵ / ₈	11 ³ / ₄	19	22 ⁷ / ₁₆	52	17 ³ / ₈		3 ³ / ₄	23 ¹ / ₄
64 - 74	4 - 10		30	25 ¹ / ₈	22 ⁵ / ₈	16 ¹⁵ / ₁₆	1 ¹ / ₈ Slot	4 ⁷ / ₁₆	22 ⁵ / ₈	31	43 ¹ / ₄	65 ¹ / ₂	22	10		28

Model R

Fig. 81-H Type F Double Upthrust

Type F Double Upthrust: The Upthrust is for support of piping or equipment from below. It has a base flange for fastening to the floor or beams. The load is supported during hydrostatic testing by means of (4) positioning studs. After testing the nuts are moved to either end of the stud to prevent interference during operation. When a Single Upthrust load from the load travel table is exceeded the Double Upthrust is recommended for sizes 50–63. Using one-half the total load, select the required hanger size from the load travel table.

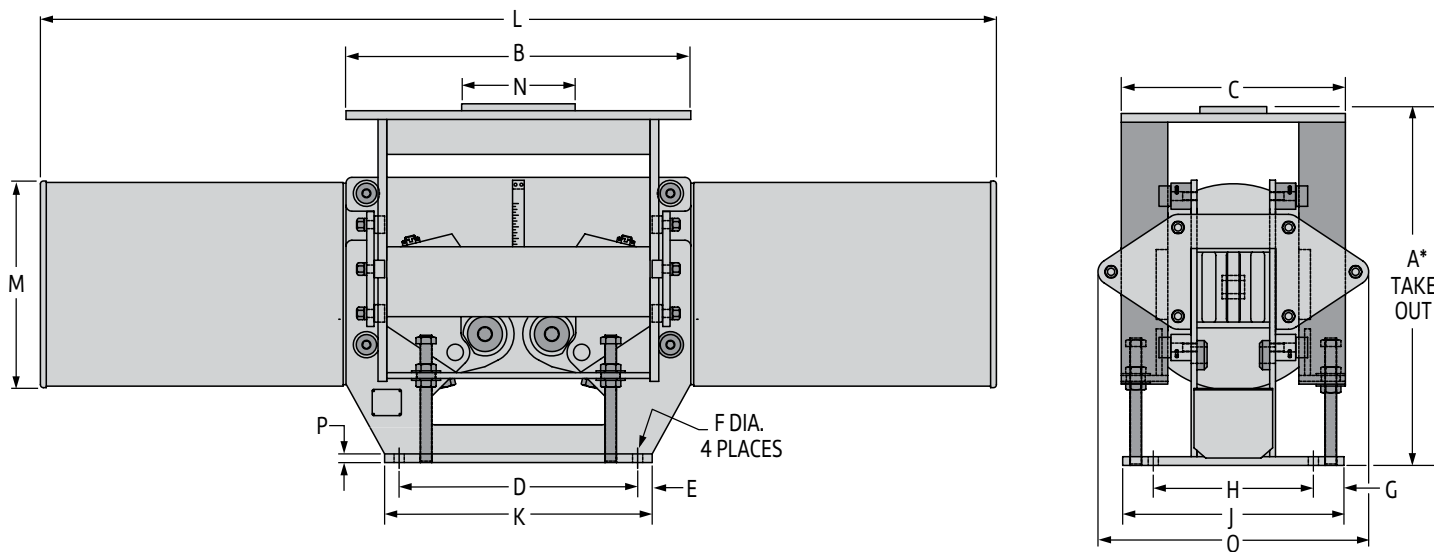
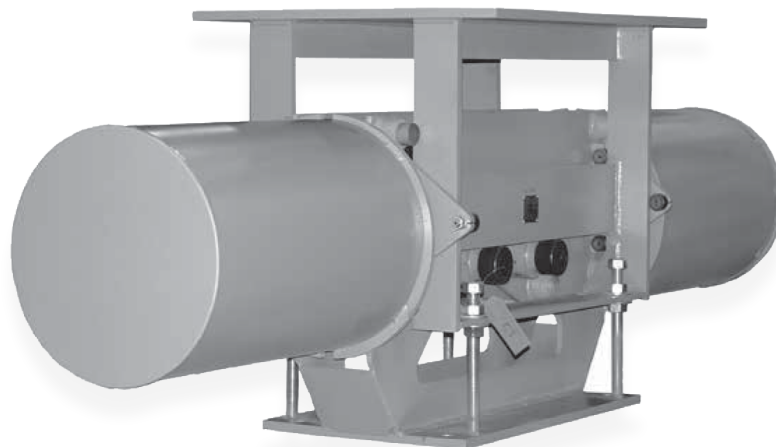
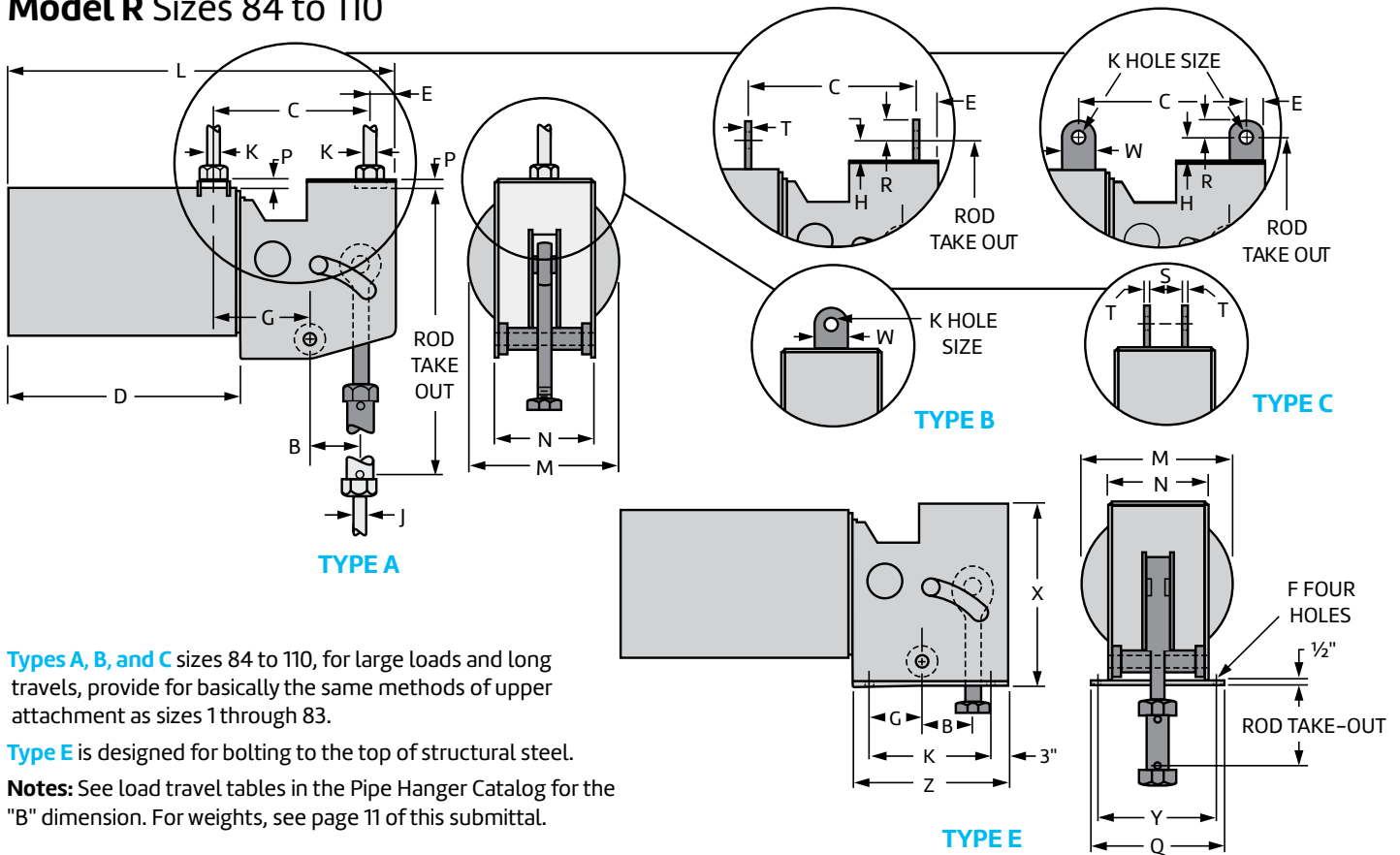

Fig. 81-H Type F Double Upthrust: Dimensions (In)

Size	Total Travel TT	A*	B	C	D	E	F	G	H	J	K	L	M	N	P	Q
50 - 63	3 - 6½	30	34½	19¼	27¾	1½	7/8	2⅝	13¾	19	30¾	91½	17⅝	10	¾	22⅝
	7 - 10	34¾	42½		34¾											

For down travel: Take-Out = "A" + (½) Actual Travel
 For up travel: Take-Out = "A" - (½) Actual Travel

**Fig. 81-H Types A, B, C, and E
Model R Sizes 84 to 110**



Types A, B, and C sizes 84 to 110, for large loads and long travels, provide for basically the same methods of upper attachment as sizes 1 through 83.

Type E is designed for bolting to the top of structural steel.

Notes: See load travel tables in the Pipe Hanger Catalog for the "B" dimension. For weights, see page 11 of this submittal.

Fig. 81-H Types A, B, C and E: Dimensions (In)

Hanger Size	L	C		D		E		F		G		H	K	M	N	P	Q	X	Y	Z	Total Travel TT	Factors			J-Rod	
		Type A&B	Type C	Type A&B	Type C	Type A,B, & C	Type E	Type A	Type B & C	Type E	Min. Thd Length											Min	Max			
84-94	76¾	28	27½	49¾	4	4½	1⅛	14	6	6	21	24	10½	3	16	34	13	27		9½ or less	45¾	54¾	21⅝	10	2	3¾
																					55½	64½	31⅝			
95-110	100	49	48½	64	4	4½	1⅜	28¾	8¾	6	30	24	11½	3½	17	37	14½	36		14 or less	56½	66	17⅝	12	2½	3¾
																					65⅝	74⅞	26⅝			

* Rod take-out = (factor) - (0.75 x TT), for lever in high position.

Load (lbs)	14,376 18,300	18,301 24,700	24,701 31,000	31,001 39,000	39,001 48,000	48,001 58,000	58,001 69,000	69,001 87,500
J & K-Rods	2	2¼	2½	2¾	3	3¼*	3½*	3¾*
K-Hole	2⅜	2⅝	2⅞	3⅛	3⅜	3⅝	3⅞	4⅛
R	3	3	4	4	4	4½	4½	4½
S	2⅞	3⅛	3⅜	3⅝	3⅞	4⅛	4⅜	4⅝
T (Type B)		¾	¾	1	1	1	1½	1¾
T (Type C)							1¼	1¼
W	6	6	8	8	8	9	9	9

* 3¼" is furnished with 4 UNC series thread.

Fig. 80-V, 81-H
Weight Chart (approx) Lbs, each

Fig. 80-V, 81-H

Hanger Sizes	Fig. 80-V			Fig. 81-H			
	Types A, B, C, D & E		Type G ■	Types A, B, C, D & E		Type F	
	Net	Shipping	Net	Net	Shipping	Net	Shipping
1 to 3	-	-	-	18	20	-	-
4 to 6	-	-	-	21	23	-	-
7 to 9	-	-	-	23	25	-	-
10 to 12	62	67	160	52	57	174	179
13 to 15	65	70	166	55	60	177	182
16 to 18	70	75	176	60	65	182	187
19 to 20	163	171	371	150	158	415	423
21 to 23	165	173	375	152	160	417	425
24 to 26	172	180	389	159	167	424	432
27 to 29	180	188	405	167	175	432	440
30 to 32	187	195	419	174	182	439	447
33 to 34	195	203	435	182	190	447	455
35 to 37	300	312	676	280	292	640	652
38 to 40	315	327	706	295	307	655	667
41 to 43	332	344	740	312	324	672	684
44 to 46	343	355	762	323	335	683	695
47 to 49	360	372	796	340	352	700	712
50 to 51	601	661	1,278	511	571	1,181	1,241
52 to 54	626	686	1,328	536	596	1,206	1,266
55 to 57	665	725	1,406	575	635	1,245	1,305
58 to 60	706	766	1,488	616	676	1,286	1,346
61 to 63	745	805	1,566	655	715	1,325	1,385
64 to 65	1,468	1,568	-	1,225	1,325	-	-
66 to 68	1,568	1,668	-	1,325	1,425	-	-
69 to 71	1,653	1,753	-	1,410	1,510	-	-
72 to 74	1,753	1,853	-	1,520	1,620	-	-
75 to 77	2,360	2,460	-	1,970	2,070	-	-
78 to 80	2,430	2,530	-	2,020	2,120	-	-
81 to 83	2,570	2,670	-	2,180	2,280	-	-
84 to 85	2,725	2,845	-	2,310	2,430	-	-
86 to 88	2,870	2,990	-	2,455	2,575	-	-
89 to 90	3,070	3,190	-	2,655	2,775	-	-
91 to 92	3,155	3,275	-	2,740	2,860	-	-
93 to 94	3,255	3,375	-	2,840	2,960	-	-
95 to 98	4,350	4,500	-	3,925	4,075	-	-
99 to 102	4,675	4,825	-	4,250	4,400	-	-
103 to 106	5,300	5,450	-	4,875	5,025	-	-
107 to 110	5,800	5,950	-	5,350	5,500	-	-

■ Based on 3'-0" C - C rod dimension and 8" total travel.